

OPERATING & MAINTENANCE MANUAL

HYL-Series Hydraulic Linear Actuators



Contents

1. General Safety Advice	3
2. Introduction	4
3. Product Description.....	5
4. Valve Actuator Model Numbers.....	6
5. Actuator Identification Plates	7
6. Typical Valve Actuator Features	8
7. Limitations of Use.....	9
8. PED (97/23/CE)	10
9. Valve Actuator Assembly Drawings.....	11
9.1 Double-Acting Valve Actuator	11
9.2 SRC Spring-Return Valve Actuator.....	12
10. Handling Instructions	13
11. Valve Actuator Mounting Instructions.....	14
12. Assembly of the Valve Actuator onto the Valve	15
12.1 DA Valve Actuators	15
12.2 SRC Valve Actuators.....	15
12.3 SRO Valve Actuators.....	15
13. Maintenance	16
13.1 Recommended Maintenance Schedule	16
13.2 Seal Replacement	17
14. Spares Kit Ordering & Additional Service Support.....	18

1. General Safety Advice

THE FOLLOWING INSTRUCTIONS SHOULD BE THOROUGHLY REVIEWED AND UNDERSTOOD PRIOR TO INSTALLING, OPERATING OR PERFORMING MAINTENANCE ON THIS EQUIPMENT. THROUGHOUT THIS MANUAL, SAFETY AND/OR CAUTION NOTES WILL APPEAR AND MUST BE STRICTLY ADHERED TO; OTHERWISE SERIOUS INJURY OR EQUIPMENT MALFUNCTION MAY OCCUR. CONTACT PALADON SYSTEMS IF IN DOUBT ABOUT ANY OF THESE INSTRUCTIONS.

Paladon Systems Srl
Loc. Ca' Verde (Strada 412/R)
29011 Borgonovo Val Tidone (PC)
Italy

Tel: +39 0523 846611
Fax: +39 0523 846659
Email: info.italia@paladonsystems.com
Web: www.paladonsystems.com



Installation, commissioning, maintenance and repair activities must be carried out by competent personnel.



Paladon Systems has taken every care in collating and verifying the contents of this manual; however, Paladon Systems does not provide any guarantee for the contents. Paladon Systems is not responsible for any mistakes contained in this manual or for any damage either accidental or via use of this manual. Any information contained within this manual is the reserved property of Paladon Systems and is subject to change without notice.

2. Introduction

The following instructions are designed to explain basic operation and maintenance for personnel performing maintenance required on models: Spring Return Open, Spring Return Close and Double Acting cylinder valve actuators.

Paladon has highly skilled service engineers available for start-up, maintenance and repair of their actuators and component parts. In addition, a scheduled training program can be conducted at Paladon Systems' workshops to train customer service and instrumentation personnel in the operation, maintenance and application of their actuators and instruments. Arrangements for these services can be made through your local Paladon Systems representative or sales office.

When performing maintenance, use only Paladon Systems replacement parts which are available from your local Paladon Systems representative or sales office. When ordering parts, please always include the Model Number and Serial Number of the valve actuator requiring maintenance.

3. Product Description

Valve Actuator Type	
SR	Spring Return Fail Open/Closed
DA	Double Acting Actuator (no spring)

- **SRO** valve actuators use hydraulic oil to extend the actuator stem and a spring to retract the stem
- **SRC** valve actuator use hydraulic oil to retract the actuator stem and a spring to extend the stem
- **DA** valve actuators use hydraulic oil for extension and retraction of actuator stem

SRC/SRO valve actuators are comprised of a hydraulic cylinder with an internal spring. Pressurizing the supply port of the valve actuator will compress the internal spring and the valve actuator stem will extend or retract as stated above. Generally the supply port for a SRO valve actuator is located at the bottom of the cylinder and the SRC valve actuator supply port is at the top of the cylinder.

4. Valve Actuator Model Numbers

Typical Valve Actuator Model Number								
HY	L	38C	12	SRC	F10	177	RS**	Rod**

Example shown

HY	Operating Method - Hydraulic (HY) or Pneumatic (PN)
L	Actuator Type - Linear
38C	Yoke Stroke Length (C = Closed Yoke)
12	Internal Cylinder Area cm ²
SRC	Actuator Type - SRC/SRO/DA
F10	Spring Identification Number
177	Rod Length
RS**	Retracted Stem Length Followed by Stroke (**) in mm
Rod**	Specified Cylinder Rod Diameter (**) in mm

5. Actuator Identification Plates

Each hydraulic linear valve actuator is provided with an Identification Plate, which is located on the actuator yoke. The **Serial Number** must be quoted when contacting Paladon Systems.

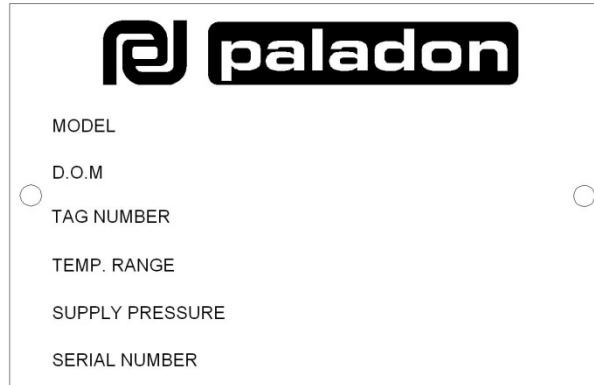

6. Typical Valve Actuator Features

- ENP coated cylinders with external tie bars where applicable
- Circular apertures sealed by 'O' rings
- Standard fixings are grade 8.8 Zinc plated with Cr3 passive protection
- Standard tie rod material is 36NiCrMo4 UNI EN 10083
- Fully adjustable end stops are provided for external adjustment and locking
- Standard operating temperatures -20°C to +55°C
- A mechanical position indicator is provided on each valve actuator
- Heavy-duty piston rod, operating sleeve bearings ensure no degradation of sealing surfaces due to working loads. Valve actuators incorporate a central guide rod which supports the combined piston and guide pin assembly throughout the stroke cycle.



Note: the actuator design can considerably change based on the customer specifications.

7. Limitations of Use



The valve actuators must be used under the limitation stated on the ID tag plates applied on the valve actuator's body, the approved Gas and the approved Inspection and Test Plan (ITP). Any failure due incorrect use of the valve actuator is the Customer's or End User's responsibility.



The valve actuator design temperature and pressure ranges are established according to the material characteristics and in no cases is the valve actuator allowed to operate outside of these ranges. Unless otherwise stated by the customer's documents, it is the Customer's responsibility to verify the suitability of materials.

8. PED (97/23/CE)

Valve actuators sold into the EU market are designed and manufactured in accordance with PED requirements, Customer's purchase order requirements and the Customer's specifications. It is not Paladon Systems' responsibility to verify PED compliance with the Customer's purchase order requirements or Customer's specification.

9. Valve Actuator Assembly Drawings

9.1 Double-Acting Valve Actuator

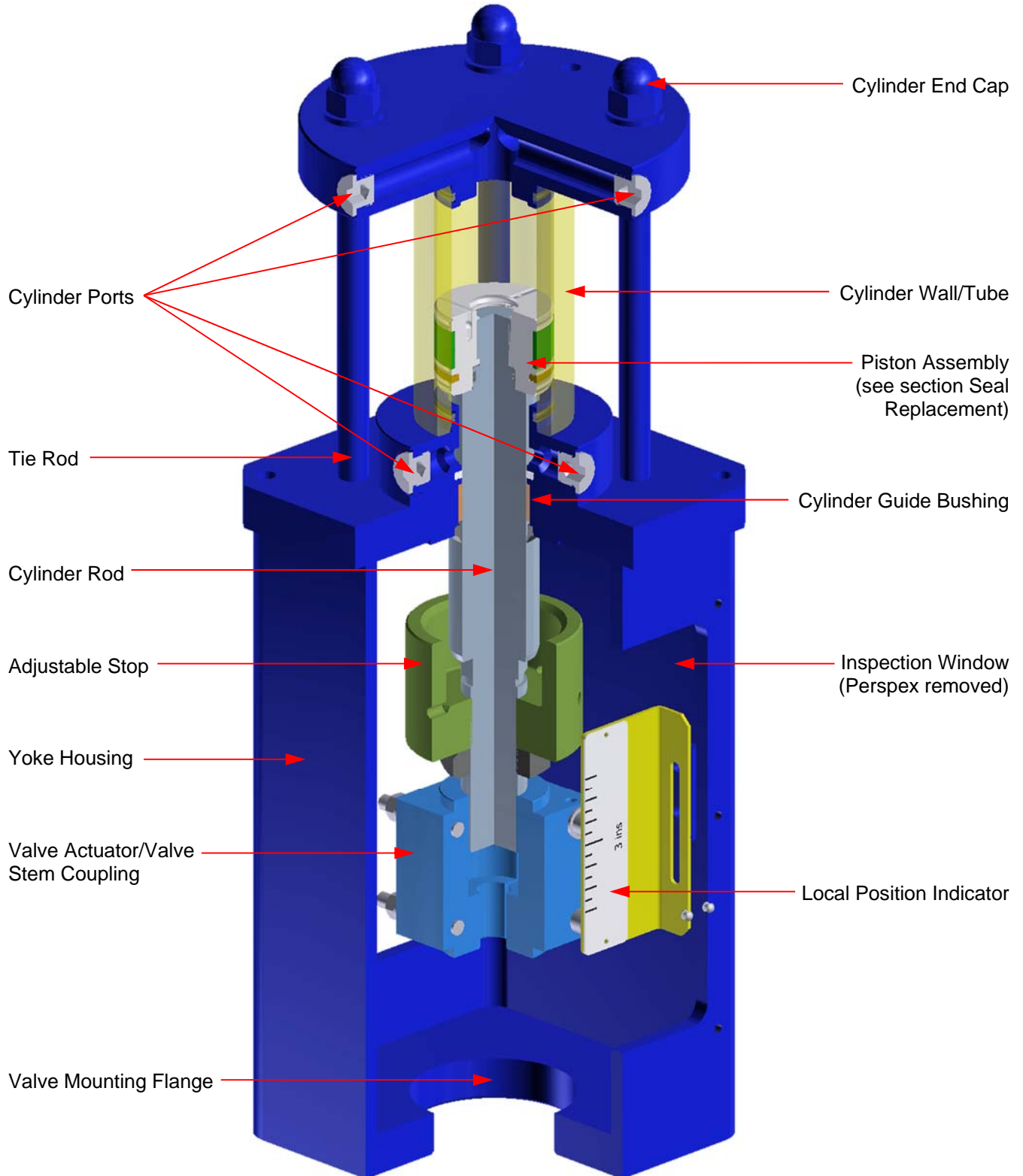

9.2 SRC Spring-Return Valve Actuator

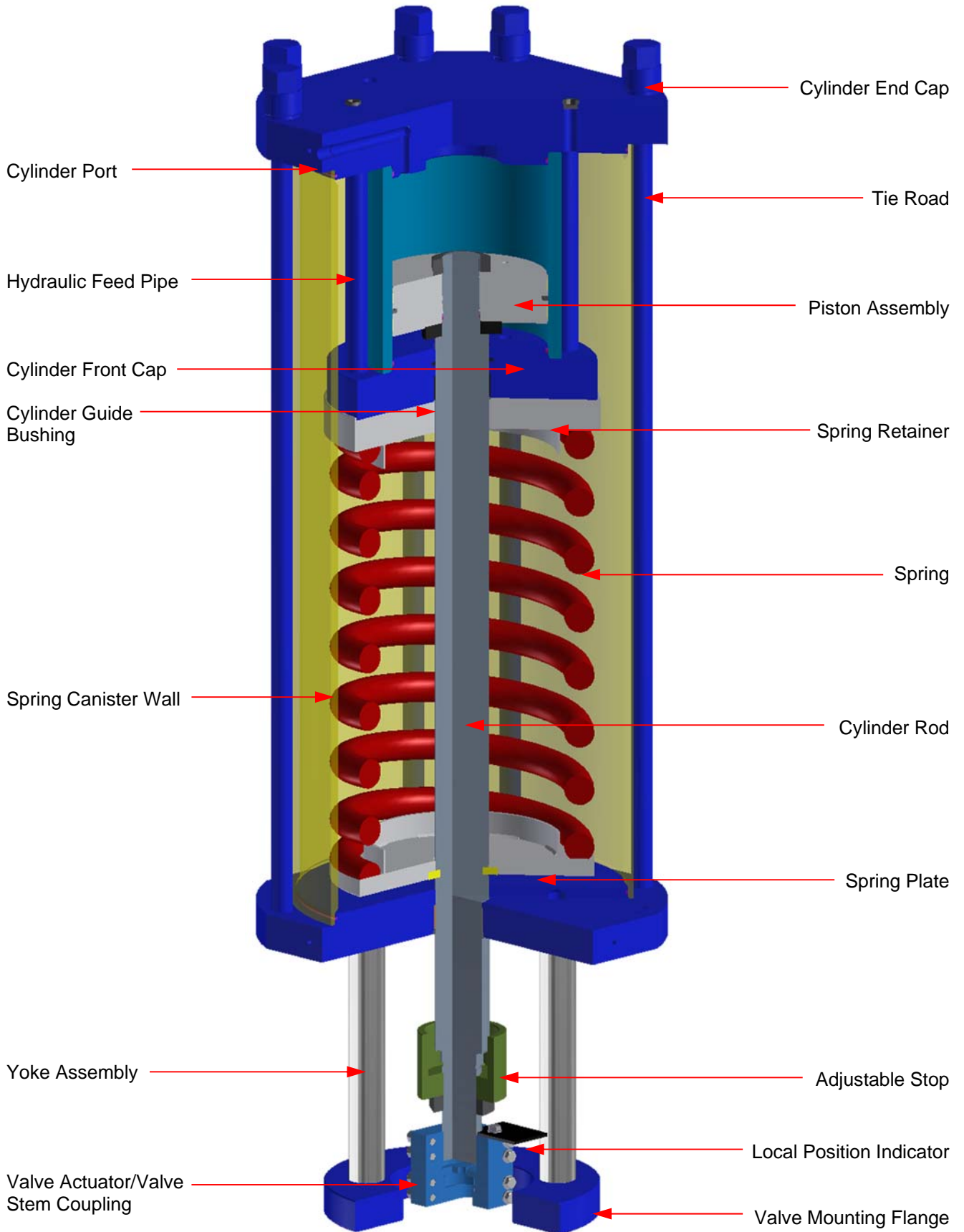

10. Handling Instructions



Paladon Systems standard valve actuators are designed for installation with valve stem in vertical position. Deviations from the standard design must be clearly highlighted in the contractual documents. Alternative orientations can be met.



Using a valve actuator in operating conditions different from what is reported in contract documents could damage the valve and result in injury to people. Paladon Systems is not responsible for improper usage.

- SRO/SRC valve actuators are shipped in their default position
- DA valve actuators are shipped in the close position
- All ports should be kept sealed/plugged until final connection to avoid contamination
- Verify the valve actuator's weight on the approved GA drawing (make sure to calculate the valve's and valve actuator's weight)
- Use suitable rated slings for lifting valve actuator



Most Paladon Systems valve actuators have lifting eyes available; however, if no lifting eyes are available please contact Paladon Systems for guidance regarding the correct lifting advice. Never lift the valve actuator and valve assembly using the valve actuator lifting points. Lift complete assemblies from the valve lifting points and use slings if no lifting points are available.

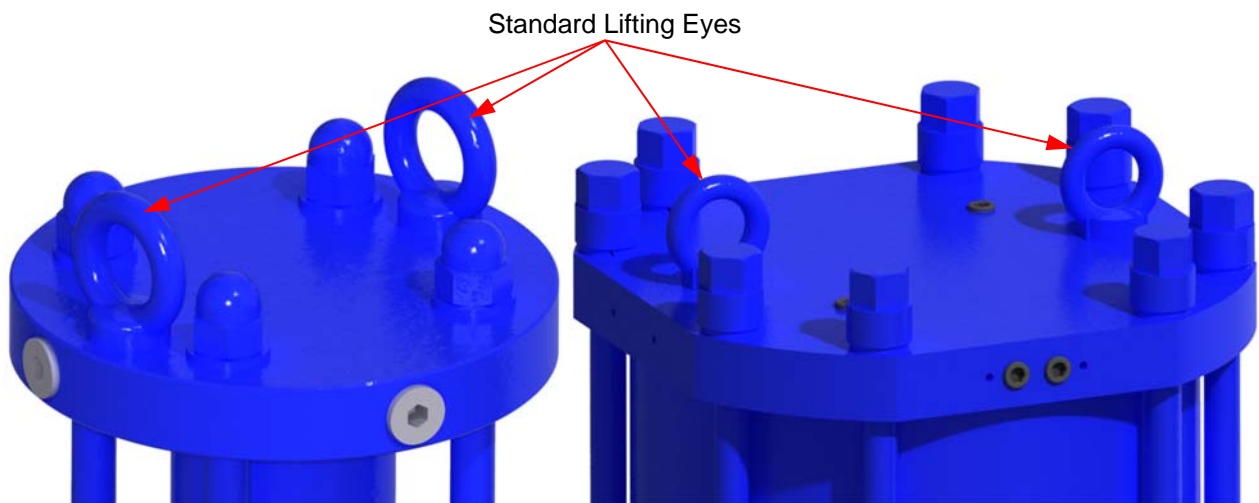

The below image is the standard lifting label attached to all SRC/SRC & DA actuators. **Do not use lifting eyes to lift actuator and valve together as lifting eyes are only rated for the valve actuator only.**

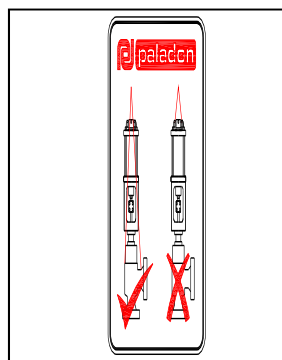

11. Valve Actuator Mounting Instructions



Ensure valve stem configuration is matched to the valve actuator coupling, specifically the thread type. The thread type should be specified in the contractual documents and relevant GA drawings.



Valve actuators designed for use in potentially explosive areas must be equipped with valves with the same class of protection. Ensure all documentation refers to the correct area. Read the valve instruction handbook before installing the valve actuator.

- Check the valve actuator's torque is suitable for the valve
- Check the coupling dimensions and thread type
- Ensure the valve is closed
- Check the actuator stroke length is suitable for the valve

Thread Size	Torque	Thread Size	Torque	Thread Size	Torque
M8	20Nm	M16	160Nm	M27	800Nm
M10	40Nm	M20	320Nm	M30	1100Nm
M12	70Nm	M22	420Nm	M33	1400Nm
M14	110Nm	M24	550Nm	M36	1700Nm

12. Assembly of the Valve Actuator onto the Valve

- Adequately support the valve with the valve stem vertical. Check all mounting faces and spigots are clean and free of paint etc. on both the valve and the actuator
- Remove the coupling if fitted and check the condition of all threaded parts
- Confirm correct assembled orientation of the actuator on the valve
- Check and confirm that the valve is in the closed position (valve stem fully retracted). Lightly grease or oil the mating faces and spigots
- Carefully lower the actuator onto the valve taking care to align any spigots and fixing holes. Check there is clearance at all times between the actuator stem and valve stem
- Secure the actuator to the valve
- Connect hydraulic supplies to the actuator

12.1 DA Valve Actuators

- Apply sufficient hydraulic pressure to ensure the valve actuator stem is fully extended. Make sure there is still a gap between the valve actuator stem and valve stem. Release the hydraulic pressure (the valve actuator stem will stay put)
- Apply sufficient hydraulic pressure to retract the valve actuator stem 3 to 5mm and hold in that position
- Fit the valve actuator/valve coupling ensuring positive engagement with both actuator and valve stems
- Adjust the actuator open stop to give the required length of stroke. Set the visual position indicator on the valve actuator
- Operate the valve actuator several times to ensure smooth operation. Check that the stroke length is repeatable

12.2 SRC Valve Actuators

- Apply sufficient hydraulic pressure to retract the valve actuator stem 3 to 5mm and hold in that position.
- Fit the valve actuator/valve coupling ensuring positive engagement with both the valve actuator and valve stems. Release the hydraulic pressure
- Adjust the valve actuator open stop to give the required length of stroke. Set the visual position indicator on the valve actuator
- Operate the valve actuator several times to ensure smooth operation. Check that the stroke length is repeatable

12.3 SRO Valve Actuators

- Apply sufficient hydraulic pressure to ensure the valve actuator stem is fully extended. Make sure there is still a gap between the actuator stem and valve stem
- Slowly release the hydraulic pressure to retract the valve actuator stem 3 to 5mm and hold in that position.
- Fit the valve actuator/valve coupling ensuring positive engagement with both the valve actuator and valve stems
- Adjust the valve actuator open stop to give the required length of stroke. Set the visual position indicator on the valve actuator
- Operate the valve actuator several times to ensure smooth operation. Check that the stroke length is repeatable

13. Maintenance



Maintenance should only be carried out by competent personnel.



SRC & SRO valve actuators require the spring to be compressed when assembled/disassembled. For further details on this operation contact Paladon Systems who will advise the best action to take.



The end user shall develop a maintenance plan based on the information given in this manual. Paladon Systems is not responsible for damages and injury caused by the lack of maintenance.

13.1 Recommended Maintenance Schedule

- Valve actuators are to be fully stroked every 6 months to prevent soft goods from uneven wear.
- Inspection of a valve actuator's exterior every 12 months.
- The valve actuator seals should be thoroughly checked by performing regular leak tests to determine whether there are any internal or external leaks.

13.2 Seal Replacement

When requiring replacement seals for DA valve actuators, ensure to quote contract number and valve actuator model/series which is located on the valve actuator's tag plate.

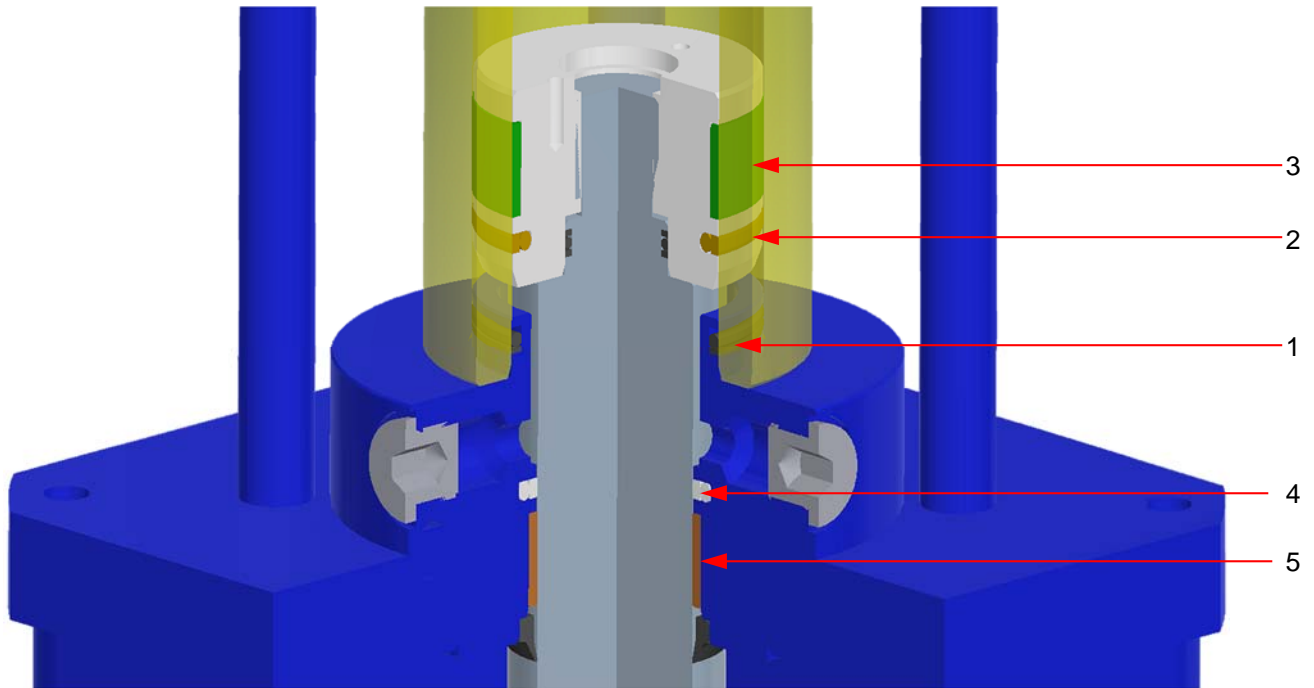

Ensure the actuator is isolated electrically and hydraulically. Bleed off any oil remaining in the cylinder.

- Systematically loosen the tie rod nuts and remove the cylinder end cap and cylinder wall/tube
- Replace cylinder tube seals (item 1)
- Replace piston seals (items 2 & 3)
- To replace cylinder seals you must remove the valve coupling and mechanical stop (see section 8.1). Slide out cylinder and unscrew rod
- Replace seals (items 4 & 5). Ensure surface is fully lubricated and seals are installed in correct direction
- Re-assemble the valve actuator

14. Spares Kit Ordering & Additional Service Support

When requesting service support or ordering spares kits, please provide the following contract details:

- Actuator Serial Number (6 or 7 digit number with a RFPL prefix)
- Paladon Contract Number (5 digit number with an ACCP, ACE, ACP, ACSP, CCP, CE, CGH, CP, CPC or CSP prefix)
- General Arrangement or Control Schematic Drawing Number
- Full Actuator Model Number(s) and Descriptions
- Tag Number(s)

Please contact your nearest Paladon representative as detailed below:

- **Paladon Systems Srl**
Loc. Ca' Verde (Strada 412/R), 29011 Borgonovo Val Tidone (PC), Italy
Tel: +39 0523 846611 Fax: +39 0523 846659
info.italia@paladonsystems.com

- **Paladon Systems Ltd**
Ferro Fields, Brixworth, Northampton, NN6 9UA, England
Tel: +44 (0)1604 880700 Fax: +44 (0)1604 882424
info@paladonsystems.com

- **Paladon Americas**
14514 Luthe Road, Houston, TX 77039, USA
Tel: +1 855 725 2366 Fax: +1 832 310 2370
info.usa@paladonsystems.com

- www.paladonsystems.com